



MAGNETIC
PRODUCTS AND SERVICES, INC.

www.gaussbusters.com

**UNDERSTANDING SHAFT
VOLTAGE AND GROUNDING
CURRENTS OF TURBINE
GENERATORS**

Paul I. Nippes, PE
Elizabeth S. Galano
2135 Highway 35
Holmdel, NJ, 07733
732-264-6651

ABSTRACT

Attendant with the current practices of extending periods between turbine-generator planned outages is the need for improved and careful condition monitoring. By determining the condition of the turbine generator units and their suitability for continuing satisfactory operation, outages can be scheduled, often preventing forced outages. A relative newcomer to the field of monitoring is shaft condition monitoring, which also usually projects to train condition monitoring. This is accomplished by placing reliable shaft-riding brushes for shaft grounding and voltage monitoring. As can be imagined, a wide plethora of shaft grounding current and voltage data is available so the issue becomes one of sifting through to identify and project hidden messages as to the shaft, and unit condition. Illustrations and descriptions of shaft grounding currents and shaft voltages, based on measurements made on installed units is the main purpose of this paper. Presented are results and practices employed over the past 25 years in monitoring turbine generator performance through interpretation of shaft grounding currents and voltages

INTRODUCTION

Stray voltages occur on rotating shafts in magnitudes ranging from micro-volts, to hundreds of volts. The former may be generated from shaft rotation in the earth's magnetic field, or induced from electromagnetic communication signal induction. The latter can be induced by shaft rotation linking asymmetric magnetism of electrical machinery, by residual magnetism present in a shaft or in adjacent stationary members and by induction from switching of power electronics, exciters and/or current-carrying brushes.

Shaft voltages can be either "friend" or "foe". As "friend", they can warn, at an early stage, of problem development long before the problem is apparent on traditional monitors and instruments. As "foe", they can, as a minimum, generate circulating currents, reducing unit efficiency and, as a maximum, the generated current can damage bearings, seals, gears and couplings, often forcing unit shutdown.

Control of shaft voltages can minimize the potential for damage. This control can be either passive, by simply placing grounding brushes, or active by injecting counteracting current signals onto the rotor. In both cases strategic brush placement and consideration is essential to satisfactory shaft grounding and signal sensing. Very important to the success of shaft grounding and signal sensing is the choice and reliability of plant grounding.

VOLTAGE AND CURRENT MEASUREMENTS

Access to the shaft for making readings and reliable grounding of the machinery can be a problem, especially where lagging covers most areas of the turbine-generator train. Usually accessible is the shaft section between the LP turbine and the generator, the normal location of shaft grounding brushes, and the generator outboard shaft extension. This location is where the bearing and seals are insulated electrically and excitation to the rotor winding enters the shaft for connection to the generator rotor winding. Traces of the grounding current have been recorded across a current shunt placed in the grounding brush cable. Traces have also been recorded to ground from a voltage sensing brush located on the generator shaft extension. These traces are presented to demonstrate typical waveforms in turbine generators. Because oscilloscope traces are but “snapshots”, graphs trending shaft grounding current and voltage peaks are also included, showing performance over extended periods of time.

The accuracy of shaft grounding current and voltage traces and profiles is highly dependent upon the reliability and stability of the ground grid. Train grounding and bonding are assured when the plant ground grid is in sound condition and there is separate bonding of train components to the ground grid (except where intentionally insulated from ground). Upper casing halves should be electrically bonded to lower casing halves maintaining an even overall casing potential. In addition, shaft grounding should be located on the shaft area between the generator and the turbine and should employ reliable shaft-riding brushes. The grounding cable should be connected from the grounding brush to the current measuring shunt, or calibrated resistor, and from there to the nearby turbine bearing casing lower half. Thus, the shaft and the bearing are set at the same potential at this location and the potential at this location is set equal to ground potential by running a ground bonding cable from the bearing lower casing to the plant ground grid. *Connecting the shaft grounding brush cable to the generator bearing bracket or frame must be avoided since the generator frame and its bearing can have voltages above ground potential due to voltage drops of generator harmonics, zero sequence currents and/or common mode currents flowing in the generator frame-to-ground bonding cable.* Voltages from these sources are peculiar to the generator and stray electrical currents could be imposed onto the shaft, possibly injecting current into other train bearings.

SHAFT GROUNDING CONSIDERATIONS

A typical steam-turbine generator without shaft grounding or where shaft grounding is ineffective or non-functioning, due to glazing of the carbon brush contact surface is shown in Figure #1. There is no protection against shaft current damage and no warning of possible problems.

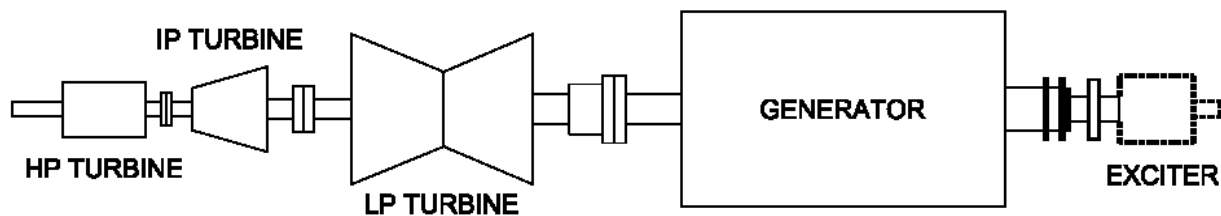

Figure 1 - No Brushes, No Monitors and No Protection

For circulating currents to occur, there has to be a shaft voltage source and there must exist, at least two contacts between shaft and frame or casing, making up a circuit for circulating current to follow. The uncertainty of these circumstances is often given, as a poor excuse, for not applying a grounding brush to the shaft of a turbine-generator. A properly performed survey can determine the existence of the driving source and the circuit.

OEM and user installed brushes are normally, and properly, mounted on the shaft between the turbine and the generator as shown in Figure 2. It is ironic that while the grounding brush grounds and protects the nearby bearing, it is also can serve as a return path for circulating currents should there be a potential shaft voltage and a single shaft rub occurs. If the brush is insulated, and all of the grounding current passes through a cable to ground, an increase in shaft grounding current can be detected by a continuous monitor. Changes in this current will provide early warning that an investigation of the cause is warranted. Sometimes, stray currents from residual magnetism are local and unmeasurable and cause damage, requiring unit disassembly and degaussing.

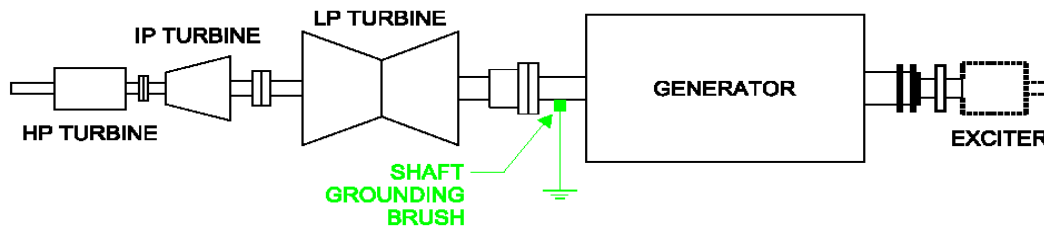

Figure 2 - Shaft Grounding, No Monitor, Possible Protection

Figure 3 shows the recommended installation of complete shaft grounding and monitoring for large and critical turbine generators. Two grounding brushes are employed with current being measured by current shunts and/or tapped resistors in the cables from the brush to the nearby turbine casing and thence to the station ground grid. Two grounding brushes provide redundancy so one brush will always be grounding the shaft while maintenance or element replacement is being made on the other brush element. The increased current carrying capacity of both brushes will protect the bearings in the event of a serious electrical fault in the generator or shaft rubs within the train.

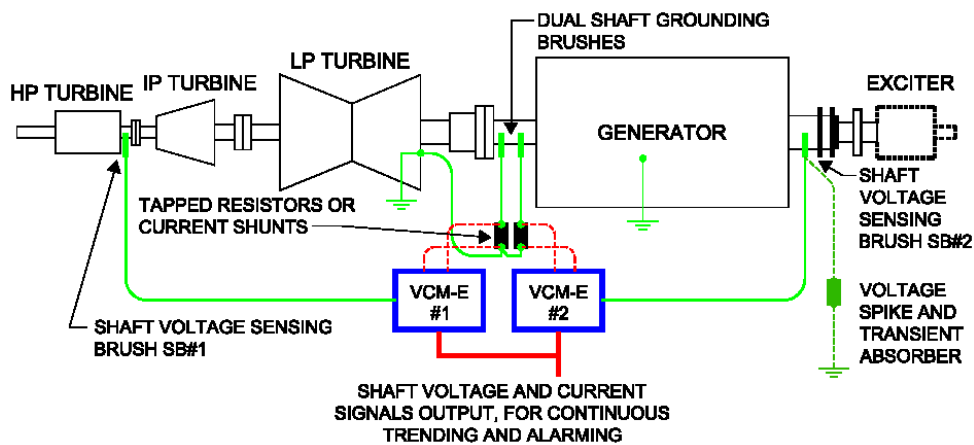

Figure 3 - Shaft Grounding, Monitoring, Protection and Warning

In addition, there are two voltage-sensing brushes, one at the turbine which will indicate voltage drop in the event of a turbine rub and will increase, should electrostatic charging take place due to wet steam in the seals or exhaust end, or possibly due to dry steam in the HP turbine. A voltage sensing brush is also placed at the generator outboard end. Its voltage will drop in the event of shaft rub or loss of bearing or hydrogen seal insulation and this will be accompanied by an increase in the shaft grounding current. High voltage at this brush with no noticeable increase in shaft grounding current usually means there are voltage spikes imposed by the excitation system, however this can be also caused by sparking collector ring brushes or a filter or diode problem in the exciter. If these are not corrected at their source, a voltage spike and transient absorber or suppressor can be placed across this brush.

Grounding of Turbine Generator shafts is often taken lightly by manufacturers and users. Their viewpoints usually change once there has been a forced outage due to high vibration, high temperature and/or bearing damage from uncontrolled shaft currents. The authors are not aware of any compelling standards governing shaft grounding and/or shaft current control. Most manufacturers supply simple grounding brushes, such as: graphite, carbon composition, silver blocks, copper straps or conductive braids. Brushes designed specifically for shaft grounding duty are slowly gaining favor.

Carbon brushes are the most commonly used brushes for shaft grounding. It is a fact that while carbon brushes are good for commutator and slip ring duty, they are unsuitable for shaft grounding duty. There are several reasons for this. One is because they cannot operate satisfactorily in presence of oil and dirt. Another is that, even on a dry, clean contact surface, satisfactory carbon brush performance is possible only when cooling air contains at least 3 grains per cubic foot (100 grains per cubic meter) of water vapor in the cooling air. A third reason is that carbon brush current density of 40-60 amperes per square inch (6-9 amperes per square centimeter) at the brush contact surface must be maintained. This current density is virtually impossible to attain at the normal very low grounding currents. If any of these conditions are not satisfied, one may expect a build up of a highly resistive glaze at the carbon brush contact surface producing arcing and over-heating (Figure 4). When copper straps are used for grounding, frequent maintenance is required as they “gum up” with dirt after only days of operation.

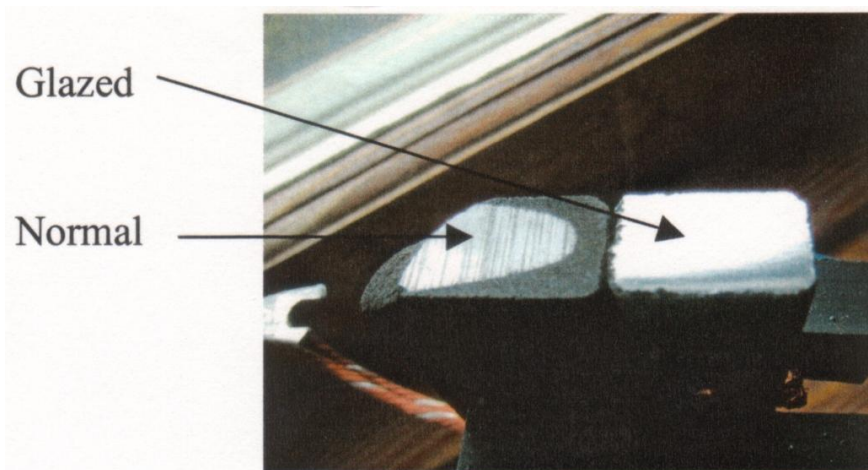

Figure 4 – Carbon Brush Contact Surface Comparison

OSCILLOGRAPH TRACES DEMONSTRATING BASIC VOLTAGE SOURCES

After reading all the above listed requirements for proper turbine generator shaft grounding the reader may expect that the oscilloscope traces presented as examples have been taken on units which fully comply with the ideal requirements for shaft grounding. Unfortunately the real world prevents finding such examples and for illustrative purposes the traces included herein have been selected from typical traces available in the files on field tests. Be assured that the selected traces accurately represent shaft currents for the conditions presented.

The two traces of Figure 5 show how one can be deceived from different traces of the same signal but taken at different time scales on the abscissa of the graph. The upper trace has a time scale of 50 nanoseconds per major division and a vertical scale of 50 millivolts per major division. Clearly one would conclude from this trace that the shaft grounding current shunt generates a pulsing 70 megahertz, 112 millivolt AC shunt voltage about an average of 50 millivolt DC shunt offset voltage.

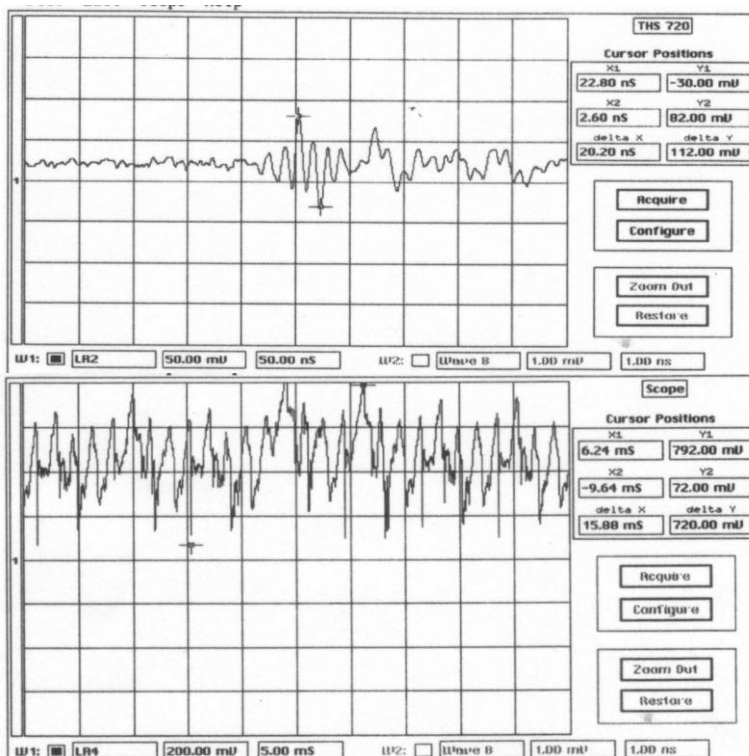

Figure 5, Upper

Figure 5, Lower

Figure 5 – Comparison of Traces with Different Time Scaling

Now consider that the lower trace is taken of the same grounding current but at a time scale 10,000 times larger than that of the upper trace. Here the predominant frequencies are 560 Hertz and 80 Hertz and the voltage is listed as 720 millivolts about an average of 400 millivolts. Which one is right? Both are! The oscilloscope traces cover entirely different time frames. It is this kind of confusion that plagues many engineers in recording and interpreting oscilloscopic traces. But what this really means can be resolved by referring to a chart of universally-employed electromagnetic frequencies. The trace shows that 70 megahertz can be found to be in the broadcasting bands for (US) television channels #2 and #4.

It is reasonable to infer that this is its source having no relation to possible damaging shaft voltages and currents. A way to resolve this issue is to set a limit on the trace abscissa time scale for displays of frequencies attendant with shaft currents and voltages.

Another confusing issue encountered when making shaft voltage traces, is erratic performance of the shaft grounding brush. This is demonstrated in Figure 6, with waveforms taken on a blower motor. The motor outboard bearing (OB) was insulated. Ungrounded shaft voltages were similar on the outboard and the inboard (IB) shaft ends, showing a fundamental with a predominant 7th harmonic, indicating a source of: winding pitch, slotting plus possible capacitive coupling to the stator winding.

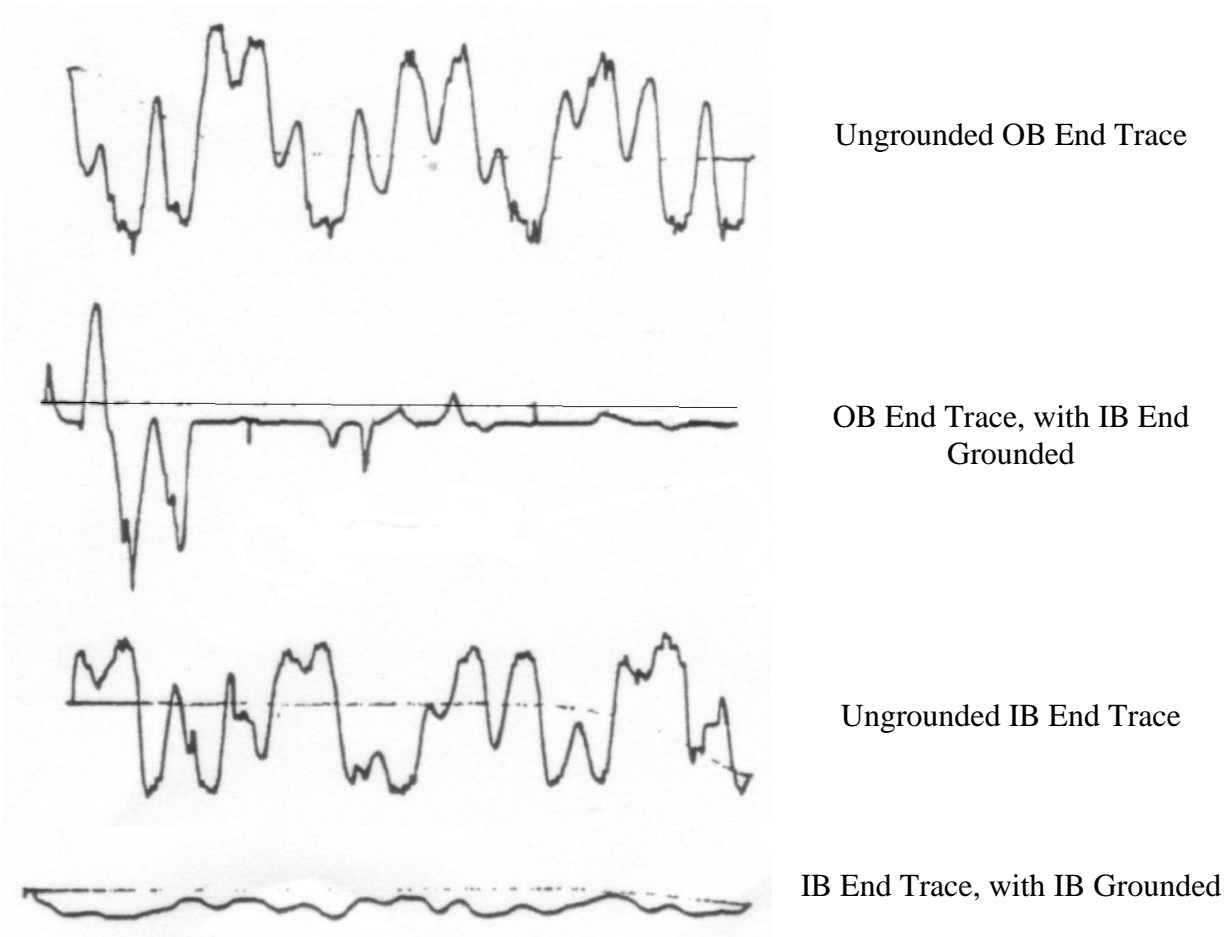

Figure 6 – Erratic Voltages on Shaft Grounding of a Blower Motor

Grounding the motor IB shaft end generally reduced the IB shaft end voltage significantly and continuously. An occasional voltage burst may indicate that grounding was momentarily lost, or possibly a component of the voltage was directed end-to-end and the OB end voltage existed as a normal condition. And when it disappeared, there was current discharging through the OB bearing, possibly doing damage, with the IB grounding brush as the return path.

Figure 7 shows a shaft voltage trace clearly from an electric machine. It is a fundamental with a strong opposing third harmonic component.

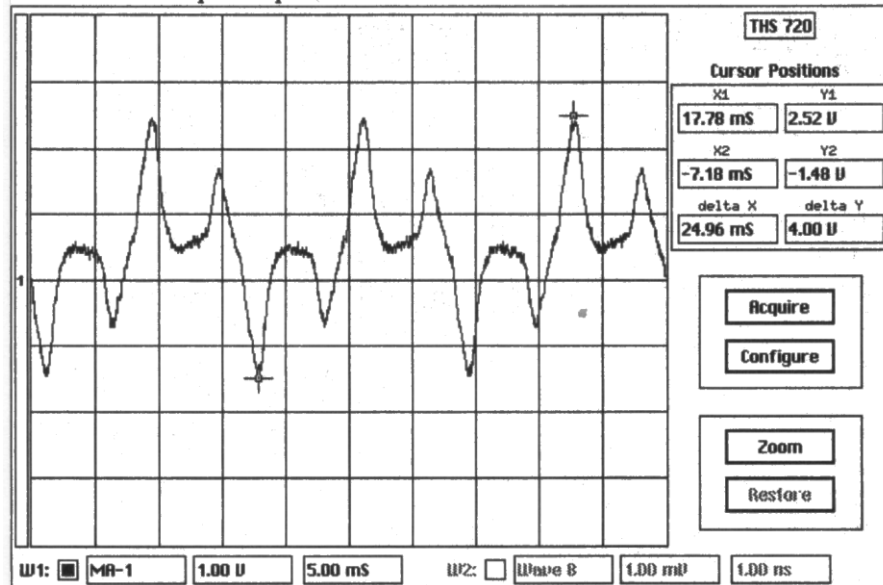

Figure 7 – Grounding Current Oscilloscope Trace at 60 Hz, Plus a Strong Common-Mode Third Harmonic

Figure 8 shows four shaft voltage traces each having different resistances in the grounding cable. Here again, the source is magnetic in nature, however, it is not clear if the source is from an electrical machine or it is from residual magnetism in either the shaft or the casing or frame of the machine. The indicator that the source is magnetic in nature is revealed by how well the grounding resistor reduces the ungrounded voltage of 40 volts. A 1k ohm resistance in the grounding cable had very little effect on the signal and the maximum voltage was still 40 volts. When the grounding resistance was reduced to 10 ohms, the shaft voltage was still 5 volts.

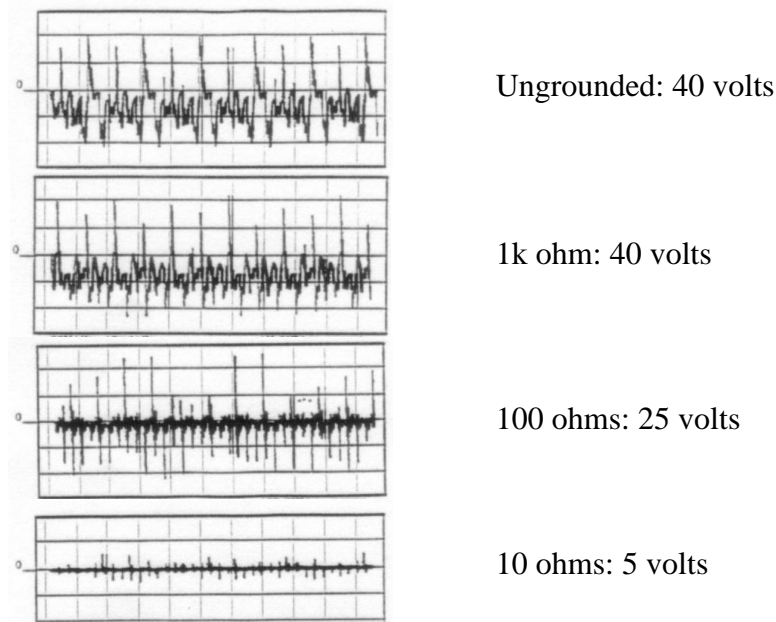

Figure 8 – Shaft Electromagnetic voltages with Different Resistances in the Shaft Grounding Circuit

Figure 9 shows three shaft voltage traces that are clearly from an electrostatic source. There is a repeated charge with sudden discharge commonly referred to as a “saw tooth” characteristic. And, in addition there is a significant reduction in voltage as resistors are inserted into the brush grounding cable. A 10k ohm resistance reduced the voltage from 30 volts to 4 volts while a 1k ohm resistor reduced the shaft voltage to less than 0.5 volts. This reduction is a considerable difference from the minimal effect for the inductive source shown in Figure 8.

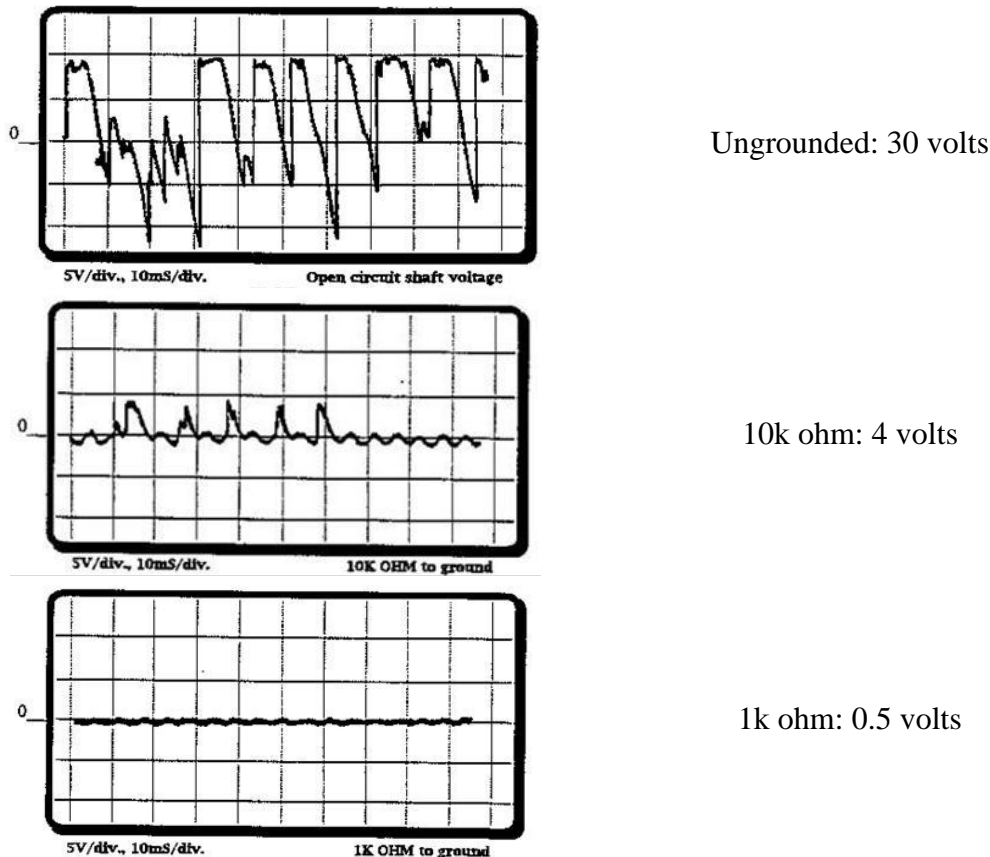

Figure 9 – Shaft Electrostatic Voltages with Different Resistances in the Shaft Grounding Circuit

SHAFT VOLTAGE AND GROUNDING CURRENT DATA COMPRESSION

As can be realized above, shaft voltages and grounding current traces are complicated and are but snapshots in time. The snapshot may not be representative of what takes place over time. A means for data “compression”, without loss of vital information was needed. Accordingly, a proprietary method for tracking signal peaks and averages continuously was developed and has been in use for at least 15 years. It is demonstrated simply on Figure 10. In this example, a graph of peaks and averages is shown using a 1995 trace on a 750MW Turbine Generator. Prediction of a possible rotor winding problem, or stator core lamination shorting, was made at that time, based upon this graph. In the year 2000, a stator coil failed due to excessive heat generated by stator lamination end packet shorting. Had this unit been base-loaded, instead of peaking duty only, an earlier failure of the coil would have been predicted. A picture of the core damage (the heating from which eventually cause a coil failure to ground) is shown on Figure 11.

Unit Condition Monitoring with the VCM-E Warns of Developing Train or Unit Problems

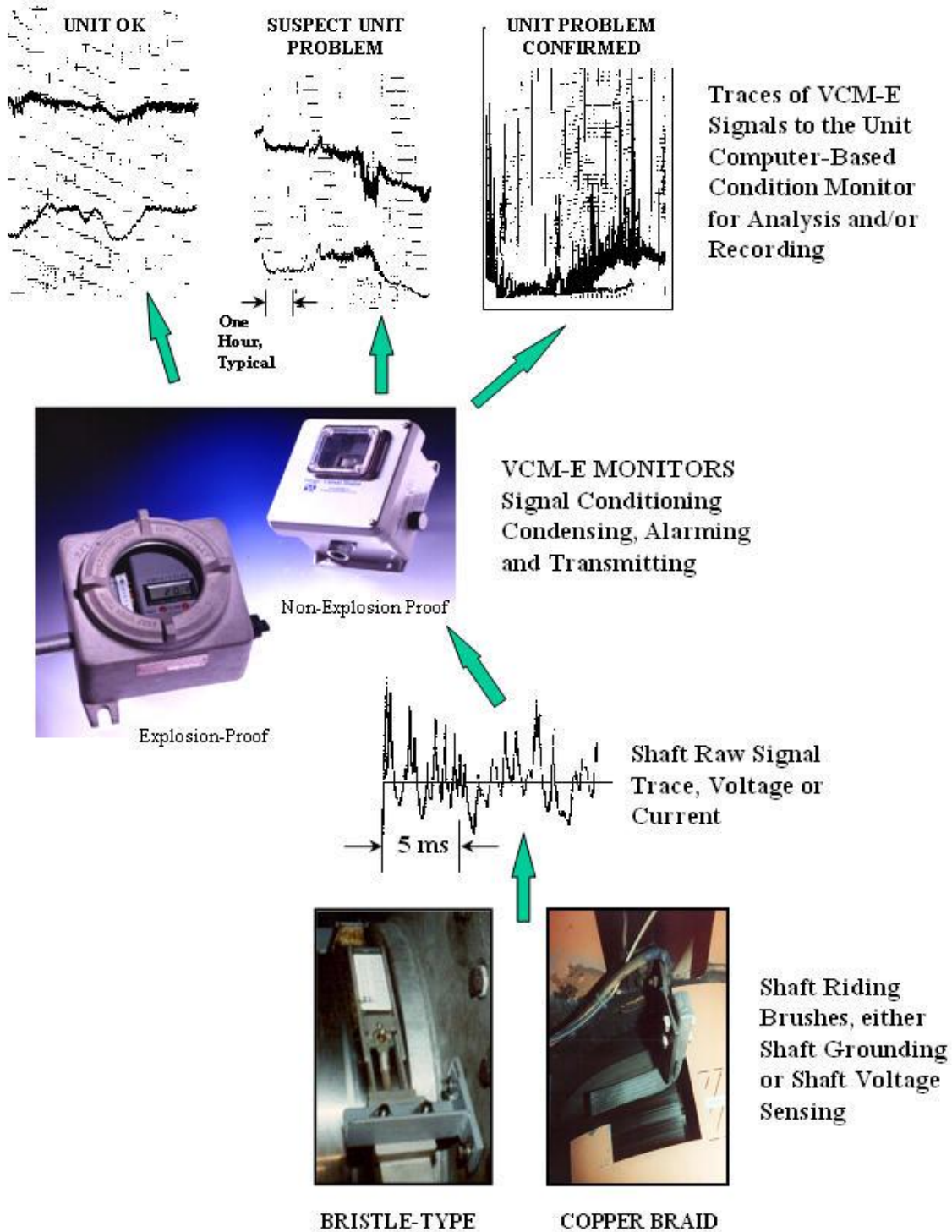

Figure 10 – Unit Condition Monitoring with the VCM-E Warns of Developing Train or Unit Problems

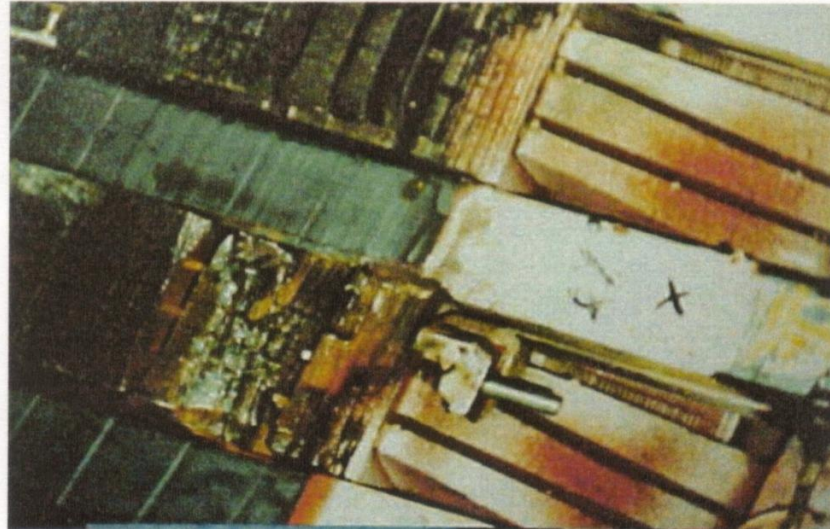

Figure 11 – Coil Failure to Ground

Figures 12 and 13 show shaft currents and voltages for 660MW turbine generators Units #1 and #2 respectively with full monitoring systems, as shown in Figure 3. These traces were made in the engineering offices of a large utility, signals being communicated in real time from the generating station. The traces show a consistency of shaft voltages and grounding currents over periods of six days and one day respectively, having no aberrations, nor indications of unit problems. Differences in currents by factors of 2 to 3 in the shaft grounding brushes is normal since they are in parallel and divide grounding current in inverse proportion to slight differences in their parallel impedances. The generator OB voltages of 23.4 and 14.0 are reasonable values with differences possibly due to exciter filter or SCR differences. If either of these values drop to a few volts or less and the shaft grounding current picks up materially, one may expect that the generator outboard bearing or seal insulation has been shorted out and bearing damage may occur.

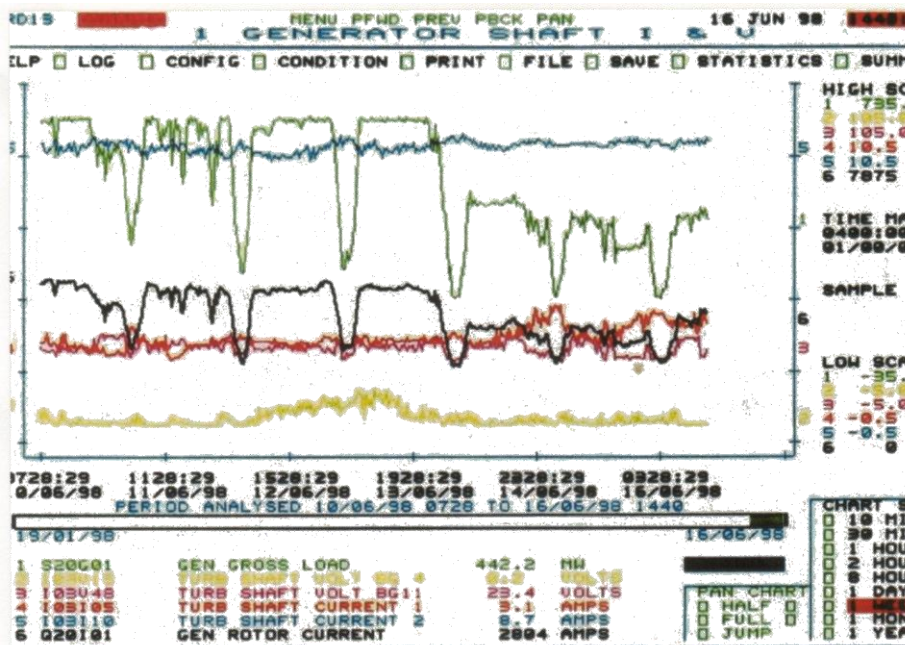

Figure 12

Unit 1 Shaft Peak Currents and Voltages for Six Days

Grounding brush Currents = 3.1 and 8.7 Amperes

Generator OB End Shaft Voltage = 23.4 Volts

Turbine Shaft Voltage = 0.2 Volts

If there is a significant rise in the generator shaft end voltage, one may expect that high excitation voltage spikes are occurring and bearing damage could occur as current spikes pass through the capacitance of the bearing insulation. Investigation of the exciter performance is in order. The turbine voltage of 0.2 volts is very safe while the 4.8 volts on unit #2 could indicate electrostatic voltage generation with possible gradual current pitting of the turbine bearings.

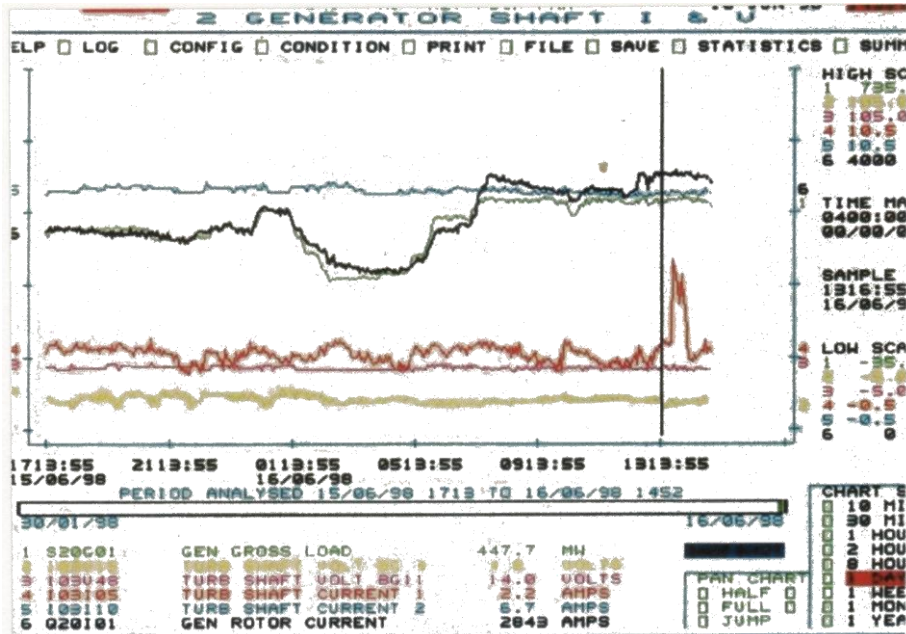

Figure 13
Unit 2 Shaft Peak
Currents and Voltages
for One Day
 Grounding brush
 Currents = 2.2 and 6.7
 Amperes
 Generator OB End
 Shaft Voltage = 14.0
 Volts
 Turbine Shaft Voltage
 = 4.8 Volts

Figure 14 (left and right) demonstrates fault detection on a 500 MW turbine generator. This unit was instrumented with an event recorder on excitation voltage and a VCM registering shaft grounding current.

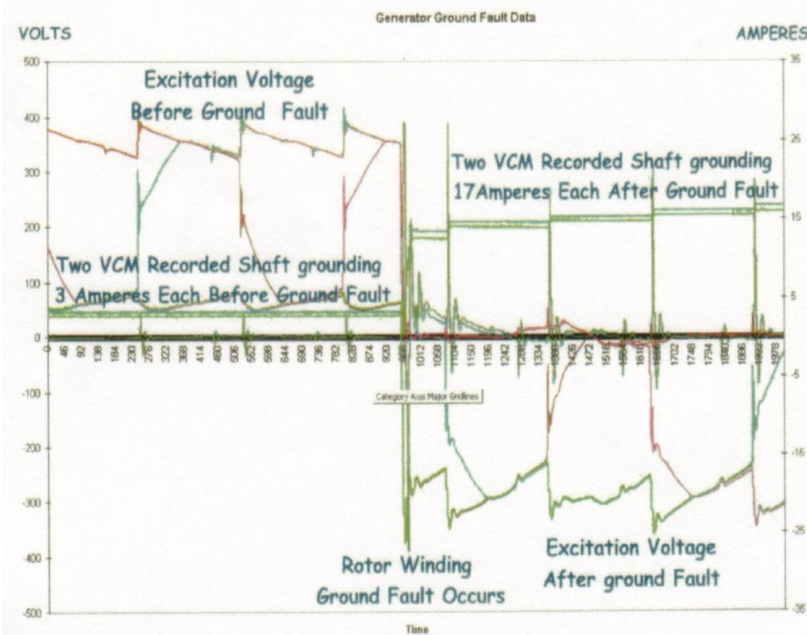

Figure 14 - 500 MW Turbine Generator Field Voltage Shift and Shaft Grounding Current Increase (Left) During a Rotor Excitation Winding Ground Fault (Right)

The reason for installing this instrumentation was that excitation ground fault indications were occurring and would disappear when the generator excitation current was reduced slightly, only to repeat the sequence after a lapse in time. The first ground fault indication with instruments in place produced the traces of Figure 14. Coincidentally, there was a significant increase in shaft grounding current from 3 amperes to 17 amperes on each of the dual shaft grounding brushes, a clear indication of the fault. Upon extensive examination the cause was traced to an intermittent ground fault in the bus bar carrying excitation current to the rotor winding. The current monitor detected and indicated very clearly the presence of an asymmetry in the generator magnetism created by the field ground fault.

SUMMARY

Shaft voltage and current monitoring should have a promising future. Turbine-generators especially need an early warning of possible problem development since many machines continue to operate in excess of their 25 to 30 year life expectancy. As users become accustomed to monitoring shaft grounding currents and voltages, they will adjust to a technology different than any other that they have previously encountered. As is demonstrated by shaft monitoring, and examples of failures detected in this paper, there are warnings requiring recognition and action by the operator. In this process, unit operation becomes more meaningful and there is a greater respect for both normal and abnormal performance indicators.

BIOGRAPHY



Paul I. Nippes, P.E., is a pioneer in solving shaft current problems and designing corrective solutions and products for Electrical and Non-Electrical Machinery Problems.

A Fellow of IEEE, Paul has served as Chairman of ANSI C50, and has been Chairman of IEC SC2G for the past 20 years. He earned a B.S.E.E. from Penn State (1950) and a MSEE from the University of Wisconsin in 1955. He was the recipient of the first Cyril Veinott Electromechanical Energy Conversion Award in 2000. For over 40 years, Mr. Nippes has served as a consultant to thousands of manufacturers and users in the industry. MPS Products are used World-wide to control and remedy Shaft Current Problems in Rotating Machinery and in any Industrial Application where magnetism disrupts processes and performance.

REFERENCES and PERIODICALS

- [1] P. Nippes, D. David and A. Peniazev, "Monitoring of Shaft Voltages and Grounding Current Brushes," presented at the EPRI Motor and Generator Predictive Maintenance & Refurbishment Conference, Orlando, FL, Nov. 29, 1995.
- [2] P. Leonard, P. Nippes, J. Sohre, B. Sandner and L. Sutherland, "Panel on Electromagnetic Shaft Current Control," presented at the 10th Turbomachinery Symposium, Texas A&M University, Houston, TX, Dec. 1981.
- [3] P. Nippes and J. Sohre, "Electromagnetic Shaft Currents and Demagnetization of Rotors of Turbines and Compressors," presented at the 7th Turbomachinery Symposium, Texas A&M University, Houston, TX, Dec. 1978.
- [4] P. I. Nippes, "Magnetism and Stray Currents in Rotating Machinery," *Journal of Engineering for Gas Turbines and Power, Transactions of ASME*, vol. 118, pp. 225-228, Jan. 1996.
- [5] J. S. Sohre, "Shaft currents Can Destroy Turbomachinery," *Power*, pp. 96-100, Mar. 1980.
- [6] J. S. Sohre, "Are Magnetic Currents Destroying Your Machinery?" *Hydrocarbon Processing*, pp. 207-212, Apr. 1979.
- [7] D. Busse, J. Erdman, R. Kerkman, D. Schlegel and G. Skibinski, "The Effects of PWM Voltage Source Inverters on the Mechanical Performance of Rolling Bearings," *IEEE Transactions on Industry Applications*, vol. 33, no. 2, pp. 567-576, Mar/Apr 1997.
- [8] D. Busse, J. Erdman, R. Kerkman, D. Schlegel and G. Skibinski, "System Electrical Parameters and their Effects on Bearing Currents," *IEEE Transactions on Industry Applications*, vol. 33, no. 2, Mar/Apr 1997.
- [9] S. T. Chen, A. Lipo and D. Fitzgerald, "Modeling of Motor Bearing Currents," *IEEE Transactions on Industry Applications*, vol. 32, no. 6, Nov/Dec 1996.
- [10] R. W. Jones and D. E. Seaver, "Investigation and Results of Eddy Currents on DC Motor Bearings," pp. 145-150, 1990.
- [11] R. Von Kreutzer and R. Schubert-Auch, Ismaning "Gefugewandlung in Lagern durch Stromubergang," *Der Maschinenschaden*, 60, heft 3, pg. 132, 1987.
- [12] L. T. Rosenberg, "Eccentricity, Vibration, and Shaft Currents in Turbine Generators," *AIEE Transactions*, pp. 38-41, Apr. 1955.
- [13] V. Schier, "Selbsterregte Unipolare Gleichstromme in Maschinenwällen," *Elektrotechnische Zeitschrift*, Nov. 1965. A translation of this article was prepared by the Associated Electrical Industries, Ltd., Power Group, Research Laboratory, Trafford Park, Manchester 17, UK, Translation #3925, "Self Excited Homopolar Direct Currents in the Shafts of Machines."
- [14] H. O. von Seinsch, "Lagerstromme bei Drehstrom-Induktionsmaschinen, Ursachen und Methoden ihrer Unterdrückung," *Conti Elektro*, pp. 43-51, Jan. 1969.
- [15] Costello, Michael J., "Shaft Voltages in Rotating Machinery," *IEEE Transactions on Industry Applications*, Vol. 29, No. 2, Mar.-Apr. 1993, pp 419-426.

Patents:

Shaft Condition Monitoring by Paul I. Nippes is covered by U. S. and International Patents 2002 and 2006.